

Centurion

Wall Mounted Eye Washer

Technical Data Sheet

Wall Mounted Eye Washer

Model:SS-B100

The Wall Mount Eye Washer is a durable wall-mounted eyewash unit that complies with EN 15154-1&2:2006, AS 4775:2007, ANSI Z358.1-2014 performance requirements. The wall-mounted style is perfect for use in settings where tight conditions prevent the use of a freestanding eyewash model. The eye washer and valve assembly is pre-built and fully water/pressure tested to ensure no leaks and proper function which ultimately reduces installation time and gives the end contractor an added peace of mind. Unit also ships with pre-assembled Stainless steel wall bracket to assist in the installation assembly.



Technical Details:

- 1.Material:**304 Stainless Steel
- 2.Eyewasher Bowl:**304 Stainless Steel
- 3.Spray Head:**ABS plastic in safety color
- 4.Valve:**Eyewasher valve is making of 1/2"SS ball valve
- 5.Flow Valve build in to avoid secondary hurt**
- 6.Water working pressure:**0.2MPA-0.8MPA
- 7.Flow control:**11.5L/Min
- 8.Standard:** EN 15154-1&2:2006, AS 4775:2007, ANSI Z358.1-2014
- 9.Gross Weight:**4.5KGS,**Net Weight:**3.7KGS
- 10.Dimension:**52cm*30cm*28cm

Stainless Steel Wall Mounted Eye Washer

Model:SS-B100

Unit:mm

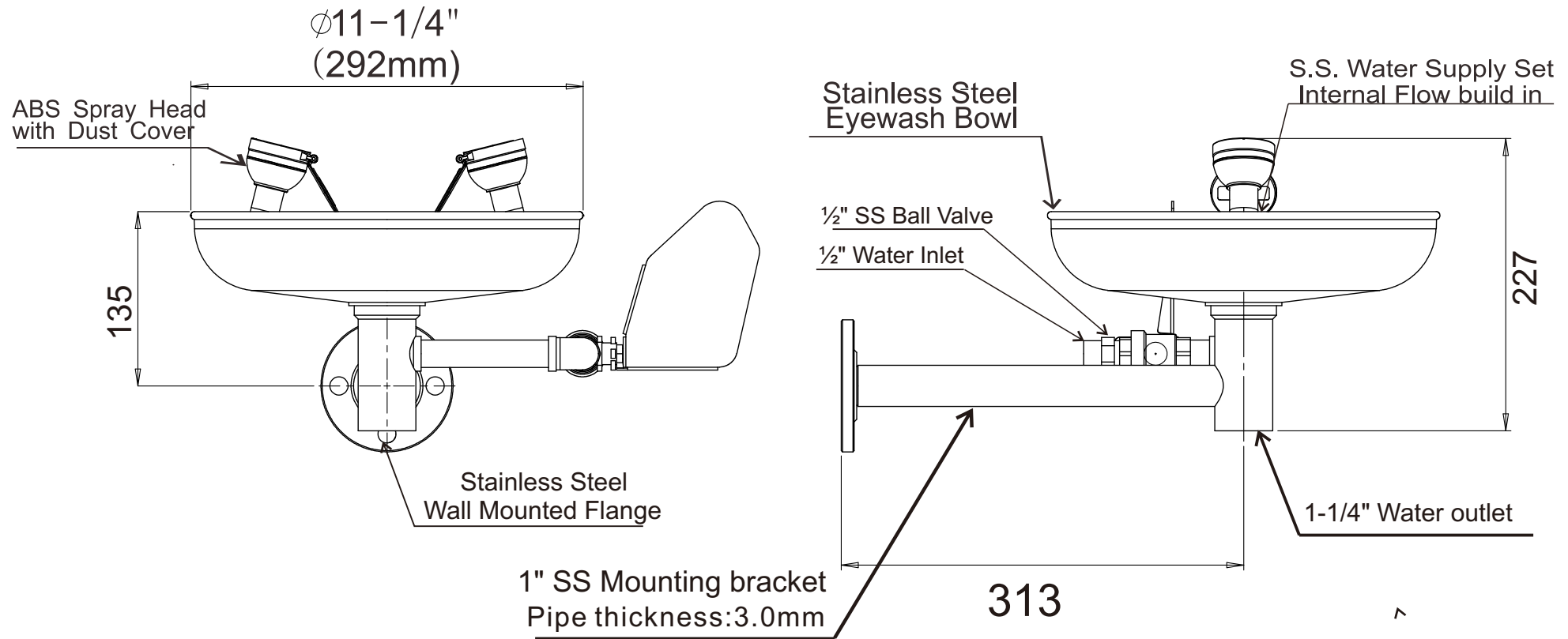

Standard Meet:ANSI Z358.1-2014
EN 15154-1&2:2006
AS 4775:2007